

Data Sheet: WPL 25 AC(S)



- › WPL-A 25 AC
- › WPL-A 25 ACS



- › Outdoor installation harvests energy from the air and turns it into comfortable heat for your home
- › Suitable for use with both in-slab and radiators
- › Increased efficiency through enhanced saturated vapour injection
- › Energy efficient inverter technology for high flow temperatures even on cold winter days
- › Very quiet operation
- › Smart Grid ready for connection to solar PV and energy management systems



WPL 25 AC(S)

COSY WARMTH FROM THE AIR IN AUSTRALIAN HOMES

The WPL 25 AC and WPL 25 ACS air source hydronic heat pumps offer an affordable entry into the energy transition for your home. Specifically engineered for outdoor installation, STIEBEL ELTRON focused on keeping the operating sound of these heat pumps to a minimum and offer the quietest system in the market.



WPL 25 AC

Model	WPL 25 AC	WPL 25 ACS
	236645	236643
Energy efficiency class	A++	A++
Rated voltage	V 400 (3 phase)	230 (single phase)
Output at A7/W35 (EN14511)	kW 14	14
Coefficient of performance at A7/W35 (EN14511)	5.09	4.82
Sound power level (EN 12102)	dB(A) 54	54
Sound pressure level at 5 m distance in a free field	dB(A) 32	32
Max. application limit on the heating side	°C 65	65
Height/Width/Depth	mm 1045/1490/593	1045/1490/593
Weight	kg 175	175

Installation requirements as per AS/NZS3000.

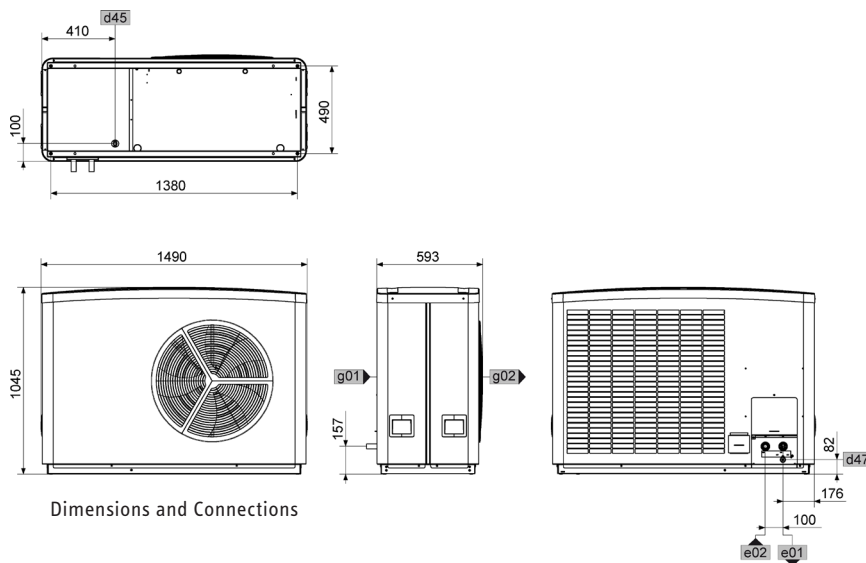

STIEBEL ELTRON is committed to our policy of continual improvement, some features may have subsequently been changed or even removed. Our advisors will be happy to consult with you regarding the currently applicable equipment features. The images used in this data sheet are for reference only.